

PBT - 01

Precision Battery Tester

User manual

All rights reserved. No part of this manual may be reproduced without permission. While every effort has been made to ensure that the contents of this manual are correct, White Wing Logic can accept no responsibility for errors or omissions.

Specifications subject to change without notice.

Important Notice

The manufacturers accept no responsibility for any damage or injury caused by the incorrect use of this product. Users must ensure that batteries are tested, used and handled in accordance with the battery manufacturer's recommendations.

Please refer to the section entitled 'Safety' for more information.

'Cyclon' is a trademark of Gates Energy Products Inc.
'Dryfit' is a trademark of Sommenschein.

If you have any comments, suggestions, or enquiries regarding this product, please write to :

White Wing Logic
142 England's Lane
Loughton
Essex IG10 2NS
United Kingdom

This product is designed and manufactured in the UK.

INTRODUCTION

The PBT-01 is a precision instrument for measuring the charge holding capacity of batteries. It can also be used as a metered constant - current source for charging Nickel-Cadmium batteries, in conjunction with an external power supply.

Although designed to test rechargeable batteries, it can also be used for 'destructive' testing of non-rechargeables, for example for incoming quality control (IQC) or evaluation purposes.

It works by applying a selectable constant-current load to the battery under test until the terminal voltage falls below a predefined 'trip' voltage, at which point the load is removed, and the capacity discharged is shown on the PBT-01's liquid crystal display as a direct reading in milliamp-hours.

In order to obtain an accurate figure for the charge holding capacity of a rechargeable battery, it is obviously important that it is fully charged before testing.

The PBT-01 can also be used to test the effectiveness of battery chargers and charging circuits within equipment, by using a battery of known capacity. This can be of use for both repair and development purposes.

Safety

When testing batteries with voltages greater than about 8 V using the 1.8 amp load setting, the heatsink on the rear of the PBT-01 will get quite hot, although not hot enough to cause injury. To prevent overheating and possible damage, ensure that air can circulate freely around the rear of the unit.

DO NOT use the PBT-01 on its back with the heatsink facing downwards.

Take care not to discharge batteries at rates higher than they are designed for - this can cause overheating and damage. As a general rule, check the battery manufacturer's data if you want to discharge at rates greater than 3C, or any maximum discharge rate indicated on the battery.

Many rechargeable batteries can supply very substantial currents if short-circuited, and pose a potential risk of fire, burns or explosion if mistreated. You must take all necessary precautions to ensure safety when handling them.

Note that the heatsink and case of the PBT-01 are not electrically isolated from the battery terminals, so take care that any leads etc. do not come into contact with it.

NEVER attempt to open up battery cells - they often contain highly corrosive and/or toxic materials. When discarding batteries, you should check with your local authority to see if there are any restrictions on the disposal of batteries with normal waste.

Controls and indicators

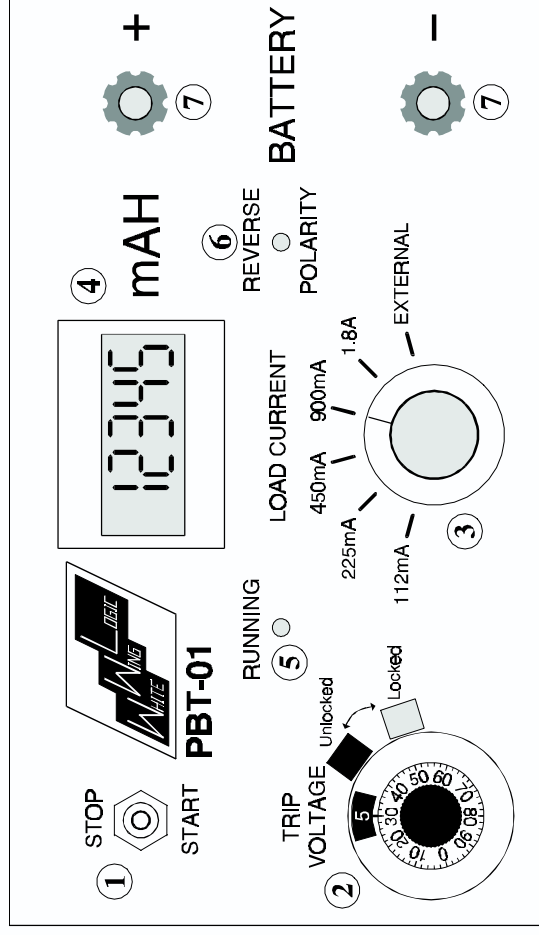

PBT-01 Front Panel

Start/Stop switch (1)

Pressing this switch downwards and releasing it starts the test process. The load is switched on, and the display is reset to zero, and starts to count as the battery is discharged. Pressing the Start/Stop switch upwards and releasing it will stop a test, removing the load and stopping the display.

Trip voltage control (2)

This is a multi-turn control, which allows the 'Trip' voltage to be set. The test will stop when the voltage across the battery under test falls below the value set using this control. The digit in the 'window' of the dial shows the whole part of the setting, and the graduated scale shows the fraction. For example to set a voltage of 6.6 volts, turn the knob so that 6 appears in the window, and the black line below the window lines up with the '60' line on the scale. The setting in the illustration above is 5.30 V.

The dial may be locked to prevent accidental adjustment, by pushing the lever on its right-hand side downwards.

Load current selector (3)

This switch selects the value of the constant-current load which will be applied to the battery when testing.

The EXTERNAL position allows the use of an external load. When using this switch position, the PBT-01 applies no load to the battery, and the display simply counts the elapsed time in seconds until the trip voltage is reached.

See the section 'Using external loads' later for more details on using external loads.

DISPLAY (4)

This display gives a continuous readout, in milliamp-hours, of the current discharged from the battery (or the time in seconds when using an external load) since the test started. While the test is running, it increments at a rate that depends on the load current selected.

Running indicator (5)

This LED flashes twice a second to show when a test is running, and the load is applied.

Reverse polarity indicator (6)

This LED illuminates if a battery is connected the wrong way round. Tests cannot be performed if this indicator is on.

End of test indication

A short audible bleep is emitted when a test stops, either because the trip voltage has been reached, or it has been manually stopped. This allows more convenient unattended testing.

Connecting up

The PBT-01 provides combined screw terminals and 4mm plug connections (7).

Connection to the battery under test should be made using good quality leads capable of carrying the test current without significant voltage drop. If lead resistance is too high, inaccurate trip voltages will result. See the next section for details of connecting up when using an external load.

Some battery packs have separate terminals used for charging. These should not be used for discharge testing, as there is often an internal diode and/or current limiter between these terminals and the battery itself.

The tester takes its power from the battery under test, and needs no other power supply.

Advanced low-power design ensures that this supply current has no significant effect on accuracy. When the battery is connected, you should see the display come on within a second or two. You may occasionally find that the tester starts running a test as soon as the battery is connected. If this happens, simply push the start/stop switch (1) up towards the STOP position.

Making a reliable connection to some types of battery pack can be difficult, especially in cases where the terminals are flat plates or studs with nothing to clip onto. In cases like these, it may be simplest to test the battery *in situ* in the equipment it is designed for, or to use a special adapter or battery holder.

Adaptors for some common battery types will be available from White Wing Logic. Please contact us for details, or to discuss requirements for custom made adaptors or battery holders.

Using external loads

When using an external load, the display indicates the time in seconds until the trip voltage is reached. The discharged capacity in Milliamp-Hours (mAH) when using an external load is given by :

$$\frac{\text{Display reading} \times \text{load current in mA}}{3600} \text{ mAH}$$

When using high external current loads (greater than 0.5 amp), care must be taken in connecting up the battery and load to ensure that the resistance of the connecting leads does not affect the accuracy of the trip voltage. The diagrams below show the various ways of connecting up, in order of preference. The thick lines indicate the parts of the wiring which will affect accuracy if their resistance is significant, so use heavy gauge wiring for these leads.

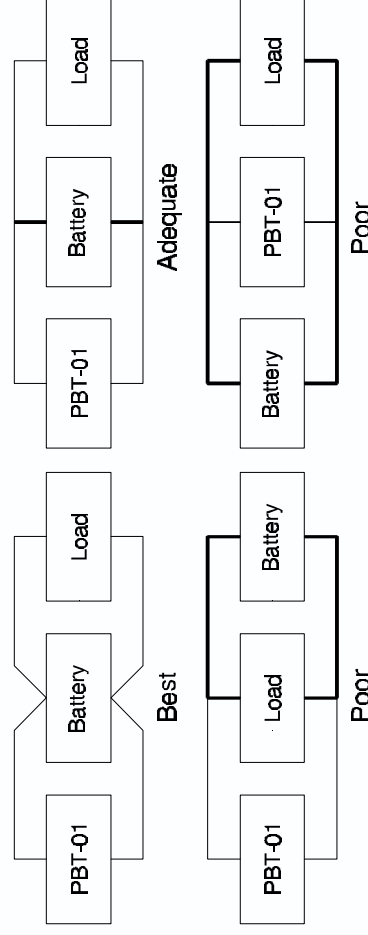

IMPORTANT : Note that as the PBT-01 cannot disconnect an external load, you must take care not to allow the load to discharge the battery completely. If the battery voltage drops below 3V, the reading on the display may be lost.

One useful application of the external load facility is to check the actual 'running time' of a particular piece of equipment on a given battery. In this case, set the trip voltage to the voltage at which the equipment stops functioning correctly, and switch on the equipment at the same as pressing the START switch on the tester.

Using the PBT-01 for charging batteries

The PBT-01 can be used with an external power supply for constant current charging of nickel-cadmium batteries. This can be useful when a suitable charger is not available, and has the advantage that the display will show a running total of the amount of charge (in mAH) applied to the battery. The diagram below shows how to connect up the PBT-01 as a charger.

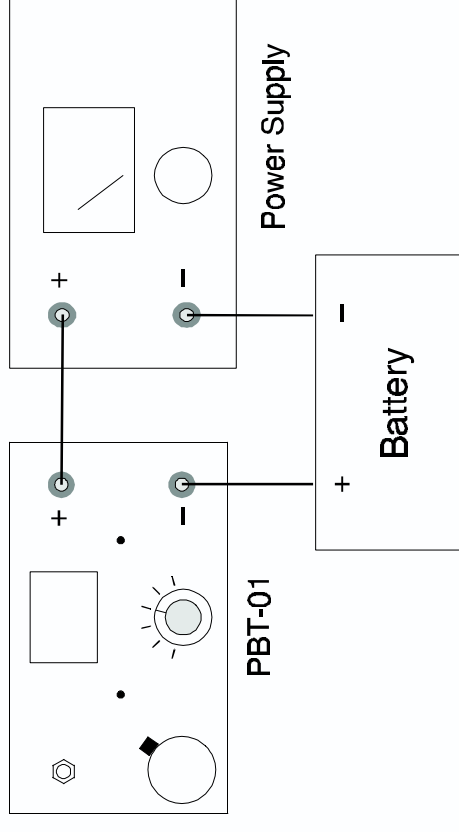

The power supply used should have an output voltage between 5 and 10 volts greater than the battery's nominal voltage, e.g. 11-16 v for a 6V battery. Good regulation is not particularly important. It should, of course be capable to supply the required charge current.

Set the required charge current using the PBT-01 load current control, and set the trip voltage to its minimum setting of 4.0v. If the PBT-01 trips when charging, increase the power supply voltage by a couple of volts.

Charging can be started and stopped using the PBT-01's start/stop switch.

The display will count to give a continuous reading of the amount of charge in mAH.

Important - you must be careful not to overcharge batteries - this circuit will NOT switch off when the battery is charged. The mAH display gives a useful indication of when to stop charging - e.g. for a 100mAH battery, you should not allow charging to continue after the display has reached 100mAH, assuming the battery was fully discharged before starting. When charging batteries that are only partially discharged, you should reduce the amount of charge accordingly.

Over-charging at low currents (e.g. 112mA) is unlikely to cause damage, but you should take great care when using high charge currents to avoid the risk of battery damage through overheating.

General notes on rechargeable batteries

The capacity of many types of rechargeable battery, including nickel-cadmium, often depends on the load current.

The graph below illustrates the discharge characteristics for a typical nickel-cadmium cell at different discharge currents.

Typical discharge curves for a nickel-cadmium cell



From this, you will see that if you test the same battery at different load currents, you will obtain slightly different mAh readings. When comparing batteries, it is therefore important to use the same trip voltage and load current.

Most rechargeable batteries are designed to have a fairly 'flat' discharge characteristic, which falls off steeply towards the end. This means that making small changes in the trip voltage settings will not have a very great effect on the mAh reading, as long as the trip voltage is sufficiently lower than the battery's endpoint voltage. For example, with the 5C curve in the above graph, there will be little difference in the mAh reading with trip voltages from 1.0 to 0.5v per cell, but a trip voltage of, say, 1.2v per cell would give a rather misleading result, especially if the battery was tested with different loads.

The endpoint voltage for Ni-Cads is often specified at 1.1v per cell at a discharge rate of C/10, where C is the capacity in mAh. You should, however, check this with the manufacturer if you want to compare test results with the capacity figure marked on the battery.

The above notes mention the voltage 'per cell'. Nickel-cadmium and lead-acid batteries have nominal cell voltages of 1.2v and 2.0v respectively, so you will find that battery voltages are multiples of these, common values being 4.8, 6.0, 7.2, 8.4v (4,5,6,7 cells) for Ni-Cad, and 6.0, 12.0 (3,6 cells) for lead-acid.

Specifications

Load current

Adjustable through six values : 0, 112, 225, 450, 900, 1800mA.

Trip voltage

Continuously adjustable 4 to 14V, via calibrated ten-turn dial. Maximum permissible voltage at terminals is 18V.

Display

Six digit liquid crystal display giving continuous readout in mAh.

Battery connection

Via combined 4mm sockets / binding posts. The unit is protected against reverse connection of the battery, and a warning LED indicates when this occurs. An internal fuse protects the battery against possible damage under fault conditions.

Accuracy

Load current : Better than 2% (5% on 112mA range).

Trip voltage : Better than 2%.

Current and trip voltage are referenced to an internal precision band-gap reference.

Time : Crystal controlled, better than 0.01%.

Power supply

The unit is powered by the battery under test. Current consumption 3mA max.

Calibration is guaranteed down to a supply voltage of 4V

Glossary of terms

- AH** Abbreviation for amp-hour, the unit used to measure battery capacity. A 1AH battery can supply 1 amp for 1 hour, or 0.5 amp for 2 hours etc. until its terminal voltage reduces to a specified value.
- C** Symbol used to denote the capacity of a battery in milliamp-hours or amp-hours. Charge and discharge rates are often expressed as a multiple of this figure, e.g. if a 100mAH battery requires a charge rate of C/10, the charge current is 10mA.
- Cyclic** Type of battery usage where the battery is repeatedly charged and discharged during normal operation, e.g. mobile radio / phone batteries.
- Cycling** The process of charging and discharging a rechargeable battery during normal use or for test purposes.
- Cyclon** A proprietary name for a type of single cell sealed lead acid battery.
- Dendrites** A form of metallic crystal growth that can occur inside nickel-cadmium batteries, eventually leading to failure due to internal short-circuiting.
- Discharge curve** The shape of a graph of battery voltage plotted against time as a battery is being discharged.
- Dryfil** Sealed type lead-acid battery. Actually a proprietary name, but often used as a descriptive term for this type of battery.
- Endpoint voltage** The voltage at which a battery is considered to have been completely discharged.
- Fast charging** A process for quickly charging Ni-Cad batteries, using a high current which is turned off automatically, either by sensing a rise in battery temperature, or a specific change in terminal voltage.
- Float charging** The process of continually charging a battery, usually for standby use in applications such as emergency lighting.
- Gel-cell** Another name for sealed-lead acid batteries, used because the acid in these batteries is in the form of a gel to avoid leakage.
- LED** Light emitting diode - used as indicator lamps on the PBT-01.
- mAh** Abbreviation for milliamp-hour, which is one thousandth of an amp-hour.
- Memory effect** A phenomenon which occurs with nickel-cadmium batteries, which occurs when batteries are only partially discharged before recharging, leading to reduced capacity. This can sometimes be remedied by a few full charge-discharge cycles.
- Ni-Cad** Abbreviation of Nickel-Cadmium Rechargeable battery
- One Hour Rate** A discharge rate which will discharge the battery in one hour, e.g. 100mA for a 100mAH battery. Other numbers may also be used, e.g. 5 hour rate for a discharge rate of C/5.
- Standby** Type of battery usage where battery is kept in a charged state ready for occasional use, e.g. emergency power supplies.